

**01700-100P .12 slide carburetor Nylon**  
**01700-100P Carburateur à tiroir .12 Nylon**

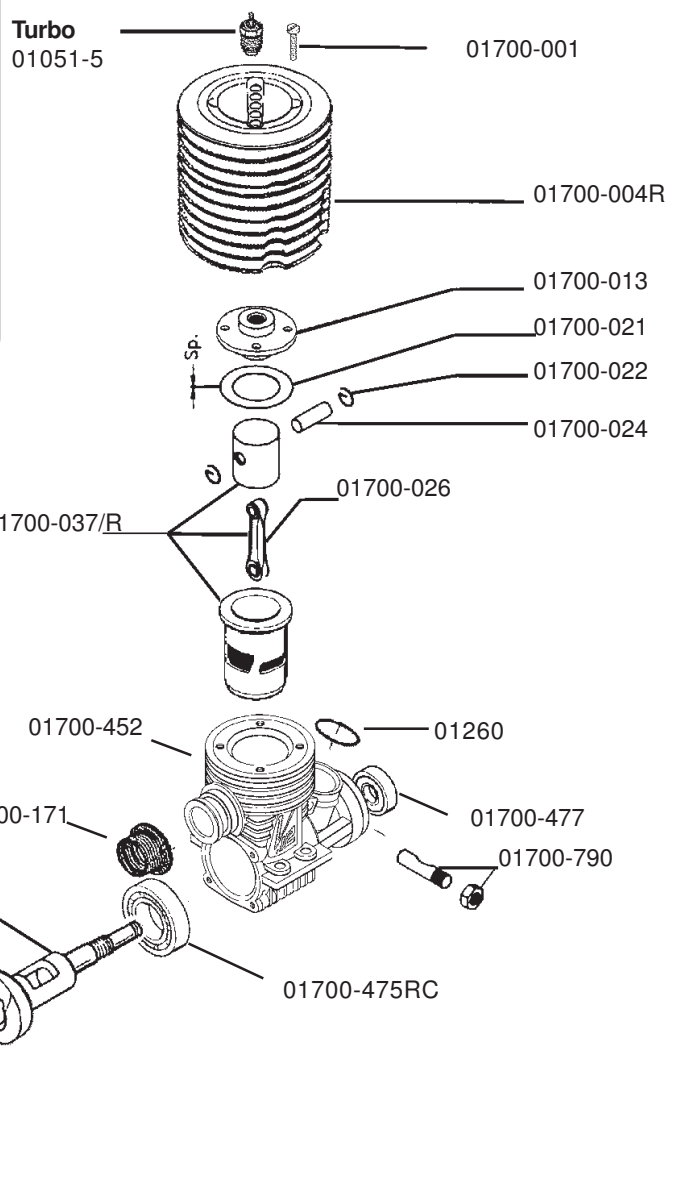
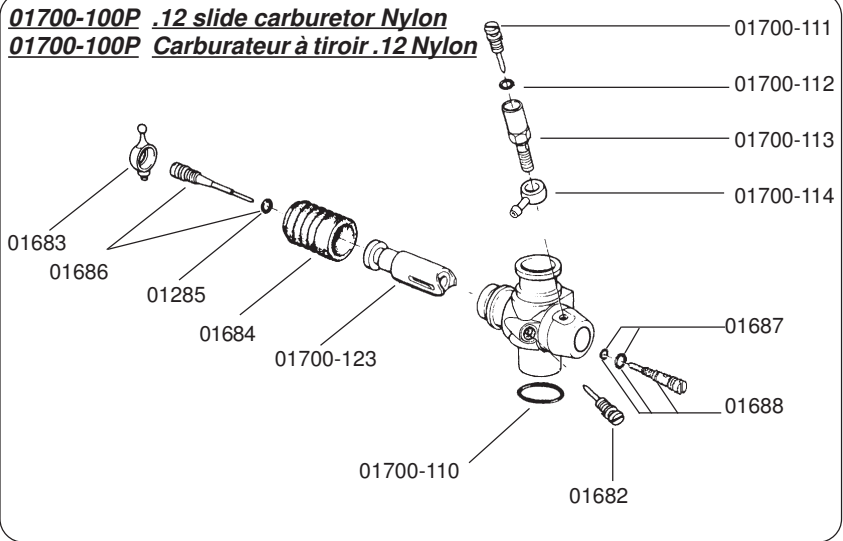

RB Products constantly improves its products, therefor changes can be made without prior notice.  
 RB Products cannot be held responsible for any kind of damage or injury during building, storage, use or abuse of any of its products.

RB Products fait évoluer constamment sa production. De ce fait, des modifications pourront être effectuées sans notifications.  
 RB Products ne pourra être tenu responsable de quelques dommages ou blessures que ce soit durant la construction, le stockage, l'usage ou l'abus d'aucun de ses produits.

## Part # 01700-000445RC

### RB Concept V12 Rody RC

Contents	Cylindrée	2.11cc
Bore	Alésage	13.8mm
Stroke	Course	14.00mm
Porting intake	Transferts	3
Porting exhaust	Echappement	1
Crankshaft	Vilebrequin	11.5mm serpent
Carburetor	Carburateur	Nylon 5.4mm
Weight	Poids	214 Gr
Compatible Glowplug	Bougies compatibles	#01051-5*
*supplied with the engine.	*livrée avec le moteur	#01051-6 #01051-7 #01051-8

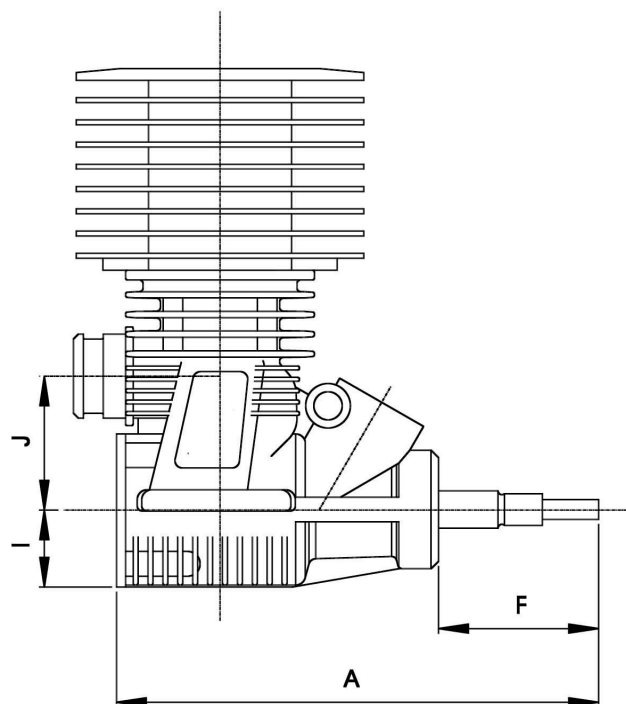
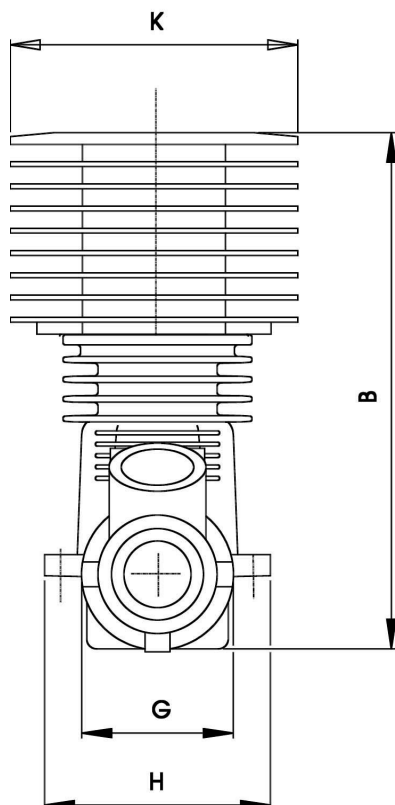
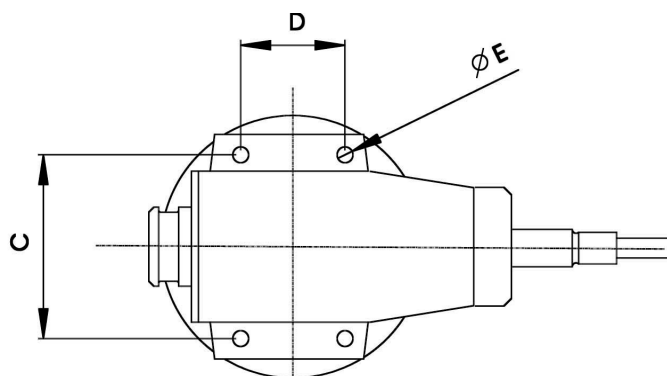

### DIMENSION (mm)

#### RB Concept V12 Rody RC

A :	80.0	G :	25.5
B :	92.0	H :	39.0
C :	31.5	I :	12.5
D :	11.0	J :	23.0
E :	3.3	K :	45.0
F :	30.0		

Crankshaft pin : Diamètre du manneton : 4.28mm

Original head shims, usable until 16% nitro

Décompression d'origine, valable jusqu'à 16% de nitro

Head shim	Joint de culasse	0.3mm (1)
		<b>0.3mm</b>

### Factory Settings:

#### Main-needle:

5 turns from closed.

#### Idle-needle :

2,5 turns from closed.

### Réglages d'usine:

#### Pointeau principal :

5 tours depuis serré à fond

#### Pointeau de reprise :

2,5 tours depuis serré à fond

### Suggested pipe/manifolds:

#1751-401 Tuned pipe IN-LINE

polished V-Concept

#1751-196 Manifold IN-LINE

conical medium polished

### Coudes/résonateurs conseillé :

#1751-401 Résonateur IN-LINE V-Concept poli.

#1751-196 Coude IN-LINE conique medium poli.

RB Products constantly improves its products, therefor changes can be made without prior notice.

RB Products cannot be held responsible for any kind of damage or injury during building, storage, use or abuse of any of its products.

RB Products fait évoluer constamment sa production. De ce fait, des modifications pourront être effectuées sans notifications.

RB Products ne pourra être tenu responsable de quelques dommages ou blessures que ce soit durant la construction, le stockage, l'usage ou l'abus d'aucun de ses produits.